

High Pulse Load Resistors

Series SWS - 2

The SWS - 2 resistor is a low ohmic, high current pulse load resistor designed for usage as a protective resistor, where no further resistor cooling is available.

As per DIN VDE 0123:1985 the SWS-2 resistor does not need any further maintenance if the resistor gets used according to the specified technical data. For safety reasons a regular visual inspection and check of ohmic value is suggested at least every 2 years, better once a year.

Because of using stainless steel material, a long life expectancy is also part of the advantages for this resistor version.

The very easy handling of the SWS -2 will be another advantage for applications where service is requested!



Dimensions:

(For example: 100mΩ resistor)

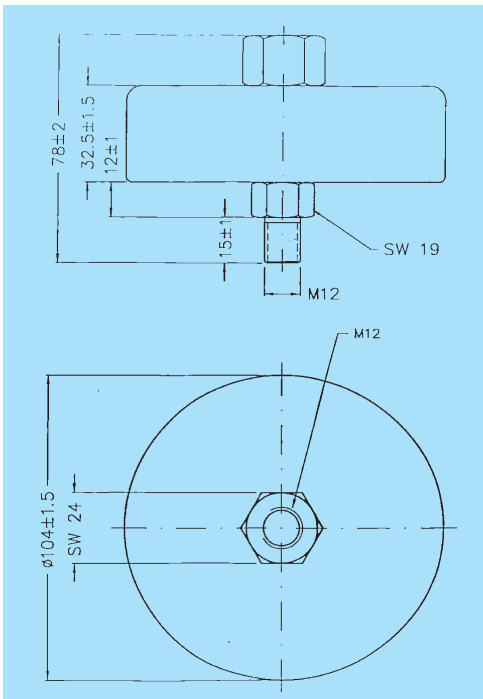

Main electrical data

Ohmic value:	< 0.5 Ohm - others on request
Tolerance:	+/- 10 % for standard, also +/-5% available
Cont. power load:	125 Watts without additional cooling
Max. peak current:	Depending on ohmic value! For example: 3,500 Amps/100ms for a 100mΩ resistor (it is suggested to perform an ohmic and visual check after such high current pulses!)
Max. peak voltage:	350V for 100ms
Max. weight:	< 1100g
Max. mounting torque:	100Nm

In the above spec sheet, you will find our standard product, please contact your local manufacturing representative or call us direct to find out details of other options available regarding this style: