

Precision High Voltage Divider

Series MTX 2000

High Power / High Voltage Dividers up to 50 Watts

The MTX 2000 series are high quality, high precision, high power, high voltage dividers for use in sophisticated resistor networks. These custom designs support a wide range of resistance values, tight voltage ratios, close tolerances, and low TCR's.

Specifications:

- Resistance Tolerance: ±0.1% to ±1%
- Ratio Tolerance: 0.1% to 1%
- Temperature Coefficient: ±25ppm/°C to ±50ppm/°C
- Ratio Temperature Coefficient: 10ppm/°C to 15ppm/°C
- Load Life: ΔR/R 0.15% max., 1000 hours at rated power
- Dielectric Strength: > 1000V (25°C, 75% relative humidity)
- Thermal Shock: ΔR/R 0.2% max.
- Moisture Resistance: ΔR/R 0.25% max.
- Operating Temperature: -55°C to +125°C
- Encapsulation: Conformal coating
- Lead Material: Nickel plated caps

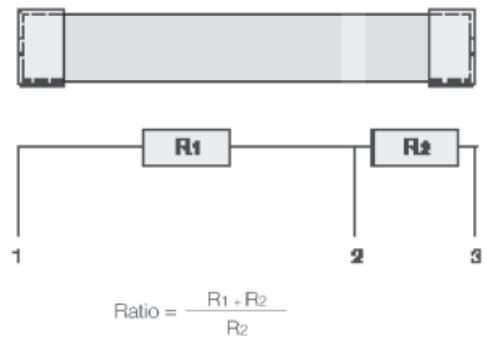
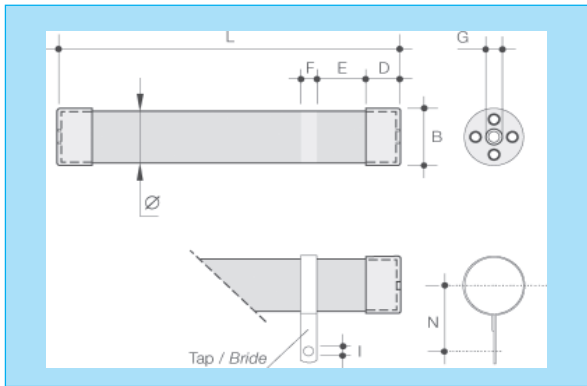

Specifications Dimensions (mm)

Type	L	B	Ø	D	E	F	G	I	N
2000.23	156 ±2	14.5 ±0.2	13.5 ±0.5	10 ±0.2	6.5 ±0.5	5 ±0.5	M4	3.2 ±0.2	18.5 ±0.5
2000.105	308 ±2.5	31.8 ±0.3	30.5 ±0.5	18 ±0.2	40 ±2	7 ±0.5	M8	3.2 ±0.2	31.5 ±0.5

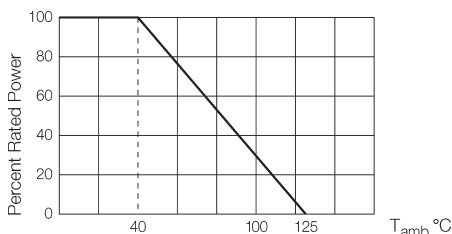

Type	Pwatt 40°C	U kVDC	TK abs.			
			50 ppm / °C	25 ppm / °C	15 ppm / °C	
2000.23	10	40	Tol. abs	1% - 0.25%	1% - 0.1%	1% - 0.1%
			TK Ratio	25 ppm / °C	15 ppm / °C	15 / 10 ppm / °C
2000.105	50	80	Tol. Ratio	0.5% - 0.25%	0.5% - 0.1%	0.5% - 0.1%
			R1 + R2 Ratio	2 M - 2 G 1 : 1000 - 1 : 20000	20 M - 1 G 1 : 1000 - 1 : 20000	20 M - 500 M 1 : 1000 - 1 : 10000
			R1 + R2 Ratio	20 M - 3 G 1 : 1000 - 1 : 20000	20 M - 2 G 1 : 1000 - 1 : 20000	20 M - 1 G 1 : 1000 - 1 : 10000

In the above spec sheet, you will find our standard product, please contact your local manufacturing representative or call us direct to find out details of other options available regarding this style: