



- Constant Voltage / Constant Current
- Last Setting Memory
- Digital Meters
- Built-in RS232 & RS485 Interface w/ GPIB optional
- Bench or Rack Mount
- Embedded Microprocessor Controller
- Voltage up to 120V, Current up to 132A

ZUP Series

Zero up programmable
Power Supplies

Specifications			ZUP6	ZUP10	ZUP20	ZUP36	ZUP60	ZUP80	ZUP120
ITEMS	MODELS	Cond.							
Load Regulation	CV		2mV + 0.005% over 0 - 100% load change						
Line Regulation	CV		1mV + 0.005% over 85 - 132 or 170 - 265VAC constant load						
Recovery Time (1)	CV		1ms	0.5ms	0.2ms				
Temperature Coefficient	CV		30ppm/°C following 30 minute warm up						
Temperature Drift (2)	CV		0.01% + 2mV change in output						
Up programming response time	CV		50 - 60ms					80ms	120ms
Down prog. resp. time (CV)	Full		50ms (70ms ZUP60-14)						
Down prog. resp. time (CV)	Zero		250ms	350ms	400ms	500ms	750ms	800ms	1000ms
Load Regulation	CC		0.01% + 5mA on 200W and 400W models, 0.07% + 10mA on 800W models						
Line Regulation	CC		0.01% + 2mA on 200W and 400W models, 0.01% + 5mA on 800W models						
Temperature Coefficient	CC		100ppm/°C from rated current after 30 minute warm up time						
Temperature Drift(2)	CC		0.02% + 5mA, 200W and 400W models, 0.05% + 10mA, 800W models						
Prog Voltage resolution	-		Better than 0.028% of rated voltage						
Prog Voltage accuracy	-		.02%+5mV	.02%+8mV	.02%+12mV	.02%+20mV	.02%+35mV	.02%+50mV	.02%+80mV
Prog Current resolution	-		Better than 0.03% of rated current						
Prog Current accuracy	-		0.4% + 40mA						
Overvoltage Shutdown	V		0 - 7.5	0 - 13	0 - 24	0 - 40	0 - 66	0 - 88	0 - 132
Thermal Protection	-		Over temperature protected						
Display - Voltage	-		3 digits (6, 20, 36, 60, 80V models), 3.5 digits (10, 120V models). Accuracy 0.2% ± 2 digits						
Display - Current	-		3 digits, (3.5 digits 132A model). Accuracy 0.5% ± 3 digits						
Display - Status	-		CV / CC, Alarm, Foldback, Local/Remote, On/Off						
Remote On/Off	-		TTL signal or dry contact relay						
Output Good	-		Open Collector						
Voltage & Current Programming	-		By either Voltage (0-4V) or Resistance (0-4k)						
Remote Sense	-		Up to 0.5V compensation per output cable						
Communication Interface	-		RS232 & RS485 standard, IEEE488 optional						
Series & Parallel Operation	-		Series: Up to two units; Parallel: Up to five units in master-slave configuration						
AC Input Voltage range	-		85-265VAC (47-63Hz)						
Inrush Current (100/200VAC) (3)	-		15/30A, 200W models, 15A, 400W models, 30A, 800W models						
Hold Up Time (Typ) at 100VAC	ms		20						
Power Factor Correction	-		Complies with EN61000-3 Class A (0.99 typ)						
Temperature Range	-		Operating: 0 - 50°C; Storage: -20 to +70°C						
Humidity (non condensing)	-		Operating: 30 - 90% RH, Storage 10 - 95%RH						
Cooling	-		Internal fan						
Withstand Voltage	-		Input to Ground 2kVAC, Input to Output 3kVAC, Output to Ground 500VAC for 1 min.						
Isolation Resistance	-		>100M at 25°C & 70%RH						
Vibration & Shock (non-op.)	-		Vibration:10-55Hz(1 min.) 2G constant X, Y, Z, when correctly mounted; Shock: <20G						
Safety Agency Approvals	-		UL3111-1, EN61010-1, CE Mark						
Conducted & Radiated EMI	-		EN55022-B conducted, A radiated, FCC Class B conducted, A radiated, VCCI-B conducted, -A radiated						
Warranty	-		3 Years						

(1) Recovery to within +/-50mV after load change of 50-100% (2) Over 8 hour period following 30 minute warm up time (3) 25°C ambient (cold start)



Model Selector								
Model	Voltage Adjust Range	Current Adjust Range	Max Power	Ripple 5Hz-1MHz mV	Noise 20MHz BW mV	Ripple 5Hz-1MHz mA	Efficiency % (100/200VAC)	Weight kg
ZUP6-33	0-6V	0-33	198	5	50	50	69 / 72	2.9
ZUP6-66	0-6V	0-66	396	5	50	100	74 / 77	3.2
ZUP6-132	0-6V	0-132	792	8	100	200	74 / 77	5.8
ZUP10-20	0-10	0-20	200	5	50	25	73 / 77	2.9
ZUP10-40	0-10	0-40	400	5	50	50	79 / 82	3.2
ZUP10-80	0-10	0-80	800	8	90	100	77 / 81	5.8
ZUP20-10	0-20	0-10	200	5	50	15	74 / 78	2.9
ZUP20-20	0-20	0-20	400	5	50	30	79 / 83	3.2
ZUP20-40	0-20	0-40	800	5	80	60	79 / 82	5.8
ZUP36-6	0-36	0-6	216	5	50	7.5	76 / 80	2.9
ZUP36-12	0-36	0-12	432	5	50	15	80 / 84	3.2
ZUP36-24	0-36	0-24	864	5	70	30	80 / 84	5.8
ZUP60-3.5	0-60	0-3.5	210	5	50	5	75 / 79	2.9
ZUP60-7	0-60	0-7	420	5	50	10	80 / 84	3.2
ZUP60-14	0-60	0-14	840	5	60	20	80 / 84	5.8
ZUP80-2.5	0-80	0-2.5	200	20	70	5	78 / 82	2.9
ZUP80-5	0-80	0-5	400	20	70	10	83 / 87	3.2
ZUP120-1.8	0-120	0-1.8	216	20	80	5	78 / 82	2.9
ZUP120-3.6	0-120	0-3.6	432	20	80	10	82 / 86	3.2

Options and Accessories		
Option	Model Suffix	Part Number
Front panel terminals (20A max) ⁵	/L ⁴	ZUP200/400/L ⁴
Front panel terminals (20A max) ⁶	/L ⁴	ZUP800/L ⁴
IEC320 cable Europe plug	/E	ZUP/E
Serial link cable RJ-45	/W	ZUP/W
GPIO Controller		GP485A
Dual Unit Assembly		NL200*
(accepts 200W or 400W models)		
19" 3U rack (accepts up to 6 200/400W models)	NL100*	
Blanking panels for NL100 (19 in. rack)	NL101*	
RS232 Communications Cable DB-9F	ZUP/NC401	
RS232 Communications Cable DB-25F	ZUP/NC403	
RS485 Communications Cable DB-9F	ZUP/NC402	
RS485 Communications Cable DB-25F	ZUP/NC404	
User Manual		NL102
* (See website for more details)		
⁴ Not available with ZUP80 or ZUP120 models.		
⁵ 200W and 400W models		
⁶ 800W models		

**For full data and drawings please visit
www.emea.tdk-lambda.com/www/zup**



Outline Drawing 200/400W

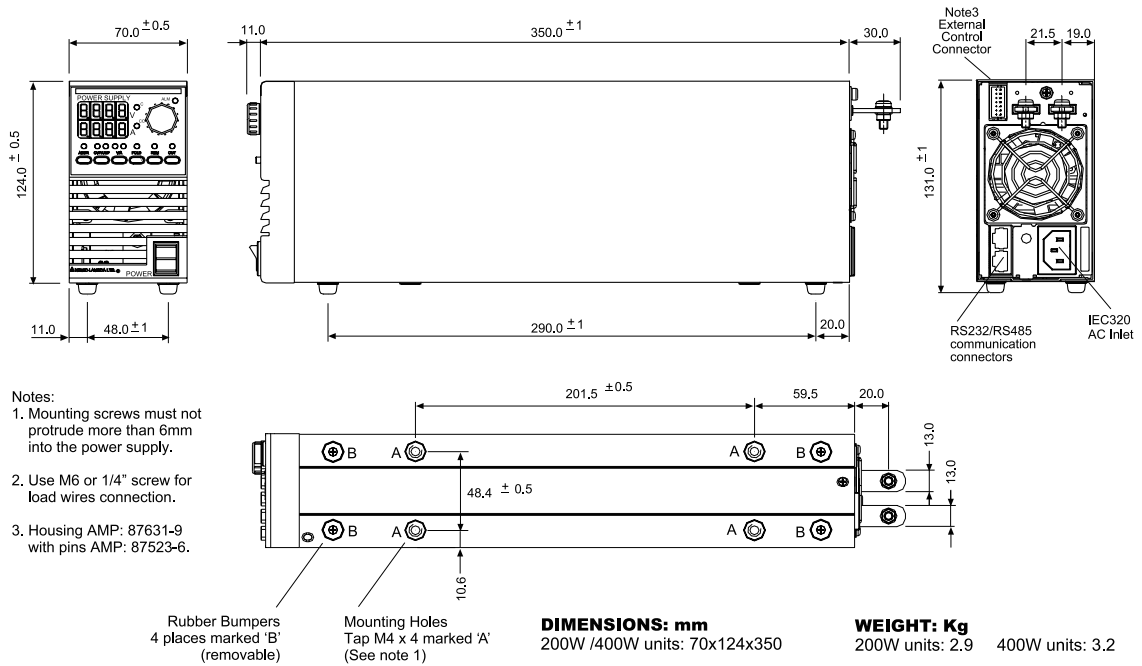

Outline Drawing 800W

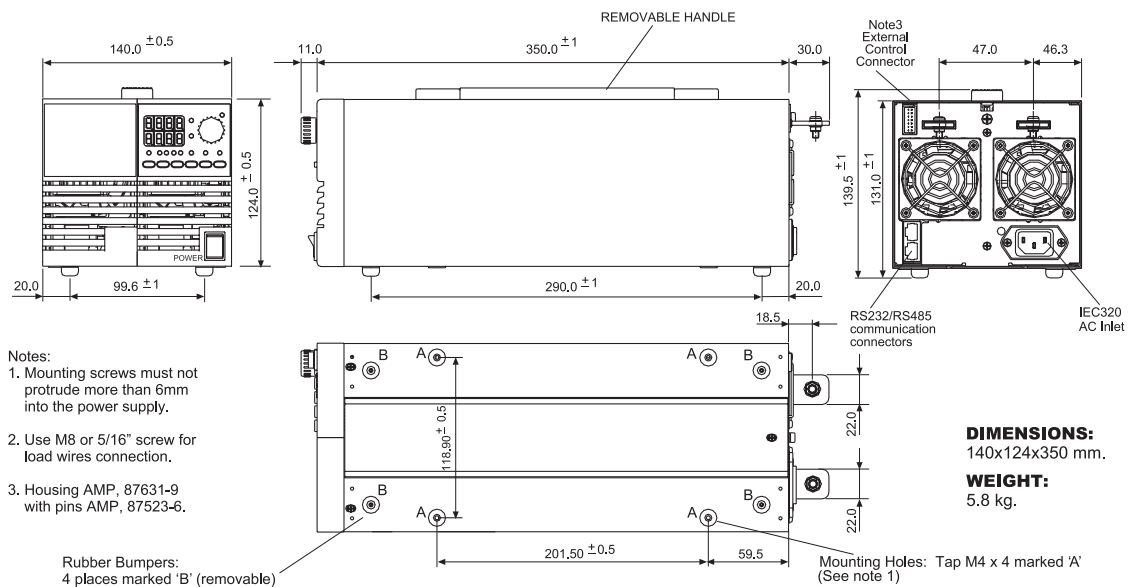



TDK-LAMBDA EMEA

www.emea-tdk-lambda.com



TDK-Lambda Germany GmbH
 Karl-Bold-Strasse 40
 77855 Achern
 Germany
 Tel: +49 7841 666 0
 Fax: +49 7841 5000
 info.germany@de.tdk-lambda.com
 www.emea.tdk-lambda.com



TDK-Lambda Italy
 Via dei Lavoratori 128/130
 20092 Cinisello Balsamo (MI)
 Italy
 Tel: +39 02 61 29 38 63
 Fax: +39 02 61 29 09 00
 info.italia@it.tdk-lambda.com
 www.it.tdk-lambda.com



TDK-Lambda Austria Sales Office
 Aredstrasse 22
 2544 Leobersdorf
 Austria
 Tel: +43 2256 655 84
 Fax: +43 2256 645 12
 info.germany@de.tdk-lambda.com
 www.emea.tdk-lambda.com



TDK-Lambda Corporation
 Nittetsu Bldg 6F
 1-13-1 Nihonbashi
 Chuo-ku
 Tokyo 103-0027 Japan
 Tel: +81 3 5201 7175
 Fax: +81 3 5201 7287
 www.tdk-lambda.com



TDK-Lambda UK Ltd.
 Kingsley Avenue
 Ilfracombe
 Devon EX34 8ES
 United Kingdom
 Tel: +44 (0) 12 71 85 66 66
 Fax: +44 (0) 12 71 86 48 94
 powersolutions@uk.tdk-lambda.com
 www.uk.tdk-lambda.com



Nemic Lambda Ltd.
 Kibbutz Givat
 Hashlosha 48800
 Israel
 Tel: +9 723 902 4333
 Fax: +9 723 902 4777
 info@nemic.co.il
 www.nemic.co.il



TDK-Lambda France SAS
 ZAC des Delaches
 BP 1077-Gometz-le-Chatel
 91940 LES ULIS
 France
 Tel: +33 1 60 12 71 65
 Fax: +33 1 60 12 71 66
 france@fr.tdk-lambda.com
 www.fr.tdk-lambda.com



TDK-Lambda Americas Inc.
 Low Power
 3055 Del Sol Blvd
 San Diego CA 92154
 USA
 Tel: +1 800-LAMBDA-4 or 1-800-526-2324
 Tel: +1 619-575-4400
 Fax: +1 619-429-1011
 www.us.tdk-lambda.com/lp/

 High Power
 405 Essex Road Neptune NJ 07753
 USA
 Tel: +1 732 922 9300
 Fax: +1 732 922 1441
 www.us.tdk-lambda.com/hp/

LOCAL DISTRIBUTION

